

---

**CATALOGUE**

<b>ON CONSIGNMENT OF THE MACHINE</b> .....	1
<b>INTRODUCTORY COMMENT</b> .....	1-2
<b>TECHNICAL DESCRIPTION</b> .....	2-3
<b>MEANING OF THE SYMBOLS</b> .....	3-4
<b>GENERAL SAFETY REGULATIONS</b> .....	5
<b>I. MACHINE PREPARATION</b>	
HANDLING THE PACKED MACHINE.....	6
HOW TO UNPACK THE MACHINE.....	6
CONNECTING THE TRACTION MOTOR (VERSIONS WITH TRACTION MOTOR).....	6
OVERALL INTRODUCTION.....	7-8
TYPE OF BATTERY.....	9
INSERTING THE BATTERIES.....	9
CONNECTING THE BATTERIES.....	9
BATTERY MAINTENANCE AND DISPOSAL.....	10
RECHARGING THE BATTERIES.....	10
BATTERY INDICATOR.....	10
INSTRUMENT PANEL COMPONENTS.....	11
ASSEMBLING AND ADJUSTING THE SQUEEGEE.....	13
RECOVERY AND SOLUTION TANK.....	14
ASSEMBLING THE SPLASH GUARD RUBBERS AND BRUSH.....	14-15
<b>II. WORK</b>	
PREPARING TO WORK.....	16
WORKING.....	16
OVERFLOW DEVICE.....	17
WORKING (VERSION WITH TRACTION SYSTEM).....	17
PARKING BRAKE (VERSION WITH TRACTION SYSTEM).....	17
AT THE END OF THE WORK.....	17
<b>III. DAILY MAINTENANCE</b>	
CLEANING THE RECOVERY.....	18
CLEANING THE SUCTION FILTER.....	18
CLEANING THE SQUEEGEE.....	18
DISASSEMBLING THE BRUSH.....	18
CLEANING THE BATTERY BOX.....	19
<b>IV. WEEKLY MAINTENANCE</b>	
CHECK THE WHEEL BRAKE.....	19
CLEANING THE SOLUTION FILTER.....	19
REPLACING THE SQUEEGEE RUBBERS.....	20
CLEANING THE SQUEEGEE TUBE.....	20
CLEANING THE WATER INLET COMPONENTS.....	21
CLEANING THE SOLUTION TANK.....	21
<b>V. TROUBLE SHOOTING</b> .....	21
<b>VI. CHOOSING AND USING THE BRUSHES</b> .....	22

**ATTENTION:**

To avoid harm to the operator and damage to the machine, please read the contents marked this symbol (  ) carefully.



ATTENTION: Danger of exhalation of gas and leakage of corrosive liquids (  )



ATTENTION: danger of fire: do not go near with free flames.

**ON CONSIGNMENT OF THE MACHINE**

When the machine is delivered to the customer, an immediate check must be performed to ensure all the material mentioned in the shipping documents has been received, and also to check the machine has not been damaged during transportation. If this is the case, the carrier must ascertain the extent of the damage at once, informing our customer service office. It is only by prompt action of this type that the missing material can be obtained, and compensation for damage successfully claimed.

**INTRODUCTORY COMMENT**

This is a TVX floor scrubber-dryer which, via the mechanical action of the rotating brush and the chemical action of a water/detergent solution, can clean any type of flooring. As it advances, it also collects the dirt removed and the detergent solution not absorbed by the floor.

Even the best machines will only work well if used correctly and kept in good working order. We therefore suggest you read this instruction booklet carefully and read it again whenever difficulties arise while using the machine. If necessary, remember that our assistance service (organized in collaboration with our dealers) is always available for advice or direct intervention.

**TECHNICAL DESCRIPTION**

Sheet 1 :

Tech Data	Unit	T45/50B	T45/50E
Clean width	mm	510	510
Squeegee Width	mm	780	780
Work capacity	M <sup>2</sup> /H	2050	2050
Pressure on the brushes	KG	35	38
Brush rotations	RPM	180	180
Brush motor	V/W	DC24/550	AC110~230/750
Suction motor	V/W	DC24/390	AC110~230/1200
Solution tank	L	45	45
Recovery tank	L	55	55
Machine dimensions (Excluding squeegee)	mm	1170x550x975	1170x550x975
Packing size	mm	1285x660x1160	1285x660x1160
Batteries	V	12Vx2	—
Wire length	m	—	15
Battery weight	KG	36x2	—
Machine weight	KG	95	95

Sheet 2:

Tech Data	Unit	T55/50B	T55/50BT	T70/65BT
Clean width	mm	510	510	690
Squeegee width	mm	780	780	780
Movement speed	KM/H	N/A	0~4.5	0~4.5
Work capacity	M2/H	2050	2250	3100
Pressure on the brushes	KG	35	35	40
Brush rotations	RPM	180	180	240
Brush motor	V/W	24/550	24/550	24/560
Traction motor	V/W	N/A	24/120	24/120
Suction motor	V/W	24/390	24/390	24/390
Solution tank	L	55	55	70
Recovery tank	L	65	65	80
Machine dimensions(Excluding squeegee)	mm	1300x550x1030	1300x550x1030	1385x720x1050
Packing size	mm	1380x660x1200	1380x660x1200	1460x800x1250
Batteries	V	12Vx2	12Vx2	12Vx2
Battery weight	KG	36x2	36x2	36x2
Machine weight	KG	110	115	130

**MEANING OF THE SYMBOLS**

**Symbols used on the machine**

Tap symbol



Indicate water regulation changes

Suction symbol



Indicate suction motor status (ON/OFF)

Brush symbol



Indicate brush motor status (ON/OFF)

Battery charging symbol



Indicate battery charging status

Squeegee position symbol

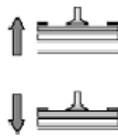

Indicate squeegee status (UP/DOWN)

Solution tank drainage symbol

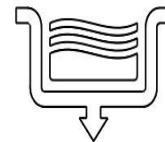

Indicate drainage of solution tank

Recovery tank drainage symbol



water inlet symbol

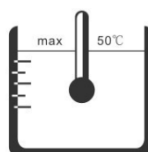

Indicate drainage of recovery tank

Indicate water inlet of solution tank

**Symbols used in the manual**



**Attention**



**Recycle**



**Manual**

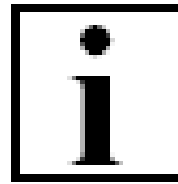

**Information**



**小心夹手**  
Mind Your Fingers

**Watch Your Hand**



**当心腐蚀**  
WARNING CORROSION

**Warning, corrosion**



**当心伤手**  
WARNING INJURE HAND

**Warning, injure hand**



**当心触电**  
Caution Shock

**Caution, shock**



**No open flames**



**危险废物**  
Hazardous waste

**Caution, dangerous waste**

## GENERAL SAFETY REGULATIONS

**The regulations below must be carefully followed in order to avoid harm to the operator and damage to the machine.**

- ◆ Read the labels on the machine carefully. Do not cover them for any reason and replace them immediately if they become damaged.
- ◆ The machine must be used exclusively by authorized, trained personnel.
- ◆ During the working of the machine, pay attention to other people and especially to children.
- ◆ Do not mix different types of detergent as this may produce harmful gases.
- ◆ Do not pack the machine when there is residual liquid in it.
- ◆ The storage temperature must be between -25 °C and +55 °C.
- ◆ Conditions of use: room temperature between 0 °C and 40 °C with relative humidity between 30 and 95%.
- ◆ Do not use the machine in an explosive atmosphere.
- ◆ Do not use the machine as a means of transport.
- ◆ Do not use acid solutions, which may damage the machine or harm the operator.
- ◆ Avoid working with the brushes when the machine is standing still, so as not to damage the floor.
- ◆ Do not vacuum inflammable liquids
- ◆ Do not use the device to collect dangerous powders.
- ◆ In the event of a fire, use a powder extinguisher. Do not use water.
- ◆ Do not knock against shelving or scaffolding, where there is a danger of falling objects.
- ◆ Select the operating speed according to the traction status.
- ◆ Do not use the machine on surfaces with an inclination greater than the one shown on the plate.
- ◆ When not in use, remove the keys and place the machine in a proper way to keep still.
- ◆ The machine is designed to carry out the washing and drying operations simultaneously. Different operations should only be carried out in areas where the passage of unauthorized persons is prohibited. Signal the presence of damp floors with suitable signs.
- ◆ If the machine does not work properly, check this is not caused by failure to carry out routine maintenance. Otherwise, request the intervention of your dealer or TVX After-sale Service Centre.
- ◆ If you need to replace any components, request the ORIGINAL spare parts from a TVX dealer or Authorized Retailer..
- ◆ Only use the brushes supplied with the device, or those specified in the Use and Maintenance Manual.
- ◆ Pull down the emergency brake immediately when there is an operation risk.
- ◆ Before carrying out any maintenance work, switch off the machine and disconnect the battery connector.
- ◆ Make sure the whole electrical connection is recovered after maintenance.
- ◆ Do not remove any protection devices which require the use of special tools.
- ◆ Do not wash the machine with corrosive substances or with pressurized water.
- ◆ Send the machine to a TVX Service Center nearby for servicing after 200 hours of use.
- ◆ To prevent the formation of scale in the solution tank filter, do not fill the tank with detergent solution many hours before using the machine.
- ◆ Before using the machine, check that all the hatches and covers are positioned as shown in this Manual.
- ◆ Before moving the recovery tank, empty the water.
- ◆ When disposing of consumption materials, observe the laws and regulations in force.
- ◆ When your TVX machine has reached the end of its long working life, dispose of the materials it contains in an

appropriate manner (e.g. oil, batteries and electric parts), and bearing in mind that the machine itself was constructed using 100% recyclable materials..

## I . MACHINE PREPARATION

### HANDLING THE PACKED MACHINE

The machine is fixed to a pallet, which is specially designed for forklift handling..

Overall dimensions of the package:

T45	T55	T70
A: 1160 mm	A: 1200 mm	A: 1250 mm
B: 660 mm	B: 660 mm	B: 800 mm
C: 1285 mm	C: 1380 mm	C: 1460 mm



It is not possible to place more than two packages on top of each other.

### HOW TO UNPACK THE MACHINE

1. Tools need to prepare:

- 1) 10mm straight shank socket wrench.
- 2) 10mm hexagonal wrench.

2. Unpack the machine

- 1) Remove the outer packaging (as figure) .
- 2) The machine is fixed to the pallet with transport holder (G) and wedges which block the wheel.
- 3) Remove the transport holder (G) by loosening the bolt (M6X35).
- 4) Remove these wedges.
- 5) Get the machine down from the pallet.
- 6) Loosen the hex bolts (M6X70)

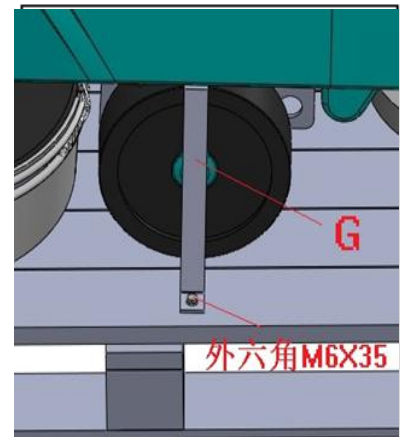
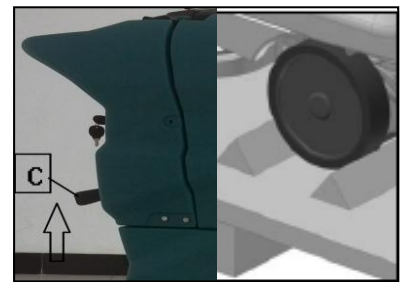

Keep the pallet and bolt (M6X70) for any future transport needs.



You are advised to fasten the bolt in long transportation.

### CONNECTING THE TRACTION MOTOR (VERSIONS WITH TRACTION MOTOR)



You are advised to have the connections made by a qualified, TVX-trained technician.

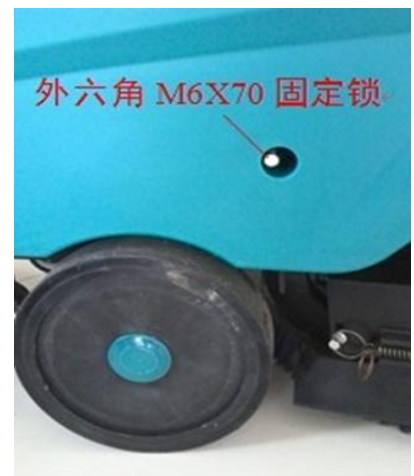

**OVERALL INTRODUCTION**

一、T45

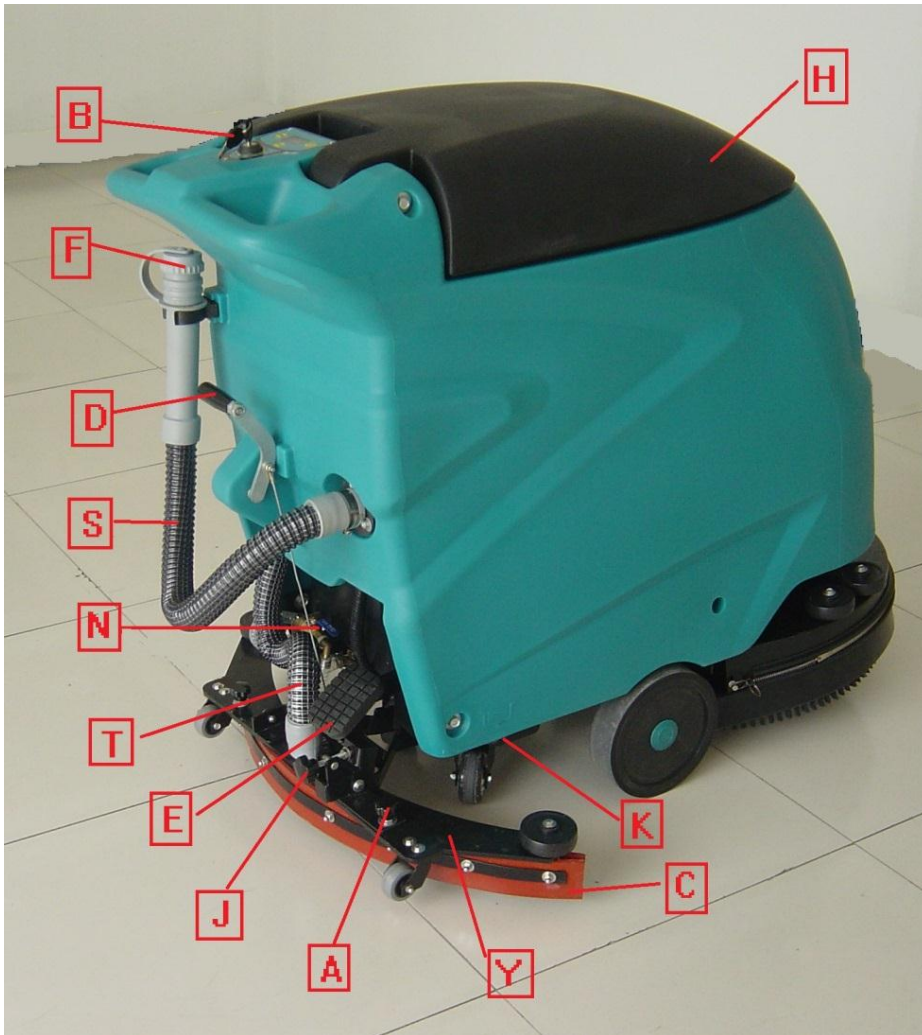

A. Squeegee fixed handle

B. Key switch

C. Rear rubber

D. Squeegee lifting rod

E. Pedal

F. Cap of the drainage

H. Recovery tank cover

J. Squeegee angle adjuster

K. Drain valve of solution tank

L. Battery wires

N. Water tap

R. Solution tank cover

S. Drainage tube

T. Suction tube

W. Battery connector

Y. Squeegee

Z. Batteries

二、T55/T70



- |                              |                             |                             |                           |
|------------------------------|-----------------------------|-----------------------------|---------------------------|
| A: Control lever             | B: Key switch               | C: Hand brake               | D: Squeegee lifting lever |
| E: Pedal                     | F: Cap of the drainage tube | G: Filter                   | H: Menu button            |
| I: Speed adjuster            | J: Angle adjuster           | K: Cap of the solution tank | L: Jumper cables          |
| M: Battery connector(female) | N: Water tap                | O: Water level tube         | P: Squeegee fixed handle  |
| Q: Squeegee                  | R: Solution tank cover      | S: Drainage tube            | T: Suction tube           |
| U: Recovery tank cover       | V: Recovery tank            | W: Battery connector(male)  | X: Solution tank          |
| Y: Rear rubber               | Z: Batteries                |                             |                           |



### TYPE OF BATTERY

To power the machine there are three types of batteries below:

- Lead-acid battery composed of liquid plumbic acid, called WET Battery.
- Liquid electrolyte lead traction batteries, called AGM Battery.
- Sealed traction batteries with gas recombination or gel technology, called GEL Battery.

### OTHER TYPES MUST NOT BE USED

Max size of the battery: Length=335mm Width=180mm Height=218mm

Max weight of the battery: 36kg.

You are advised to only lift and move the batteries with lifting and transportation means suitable for the specific weight and size.

Connect two 12V batteries in series to obtain a voltage of 24V on the clamps. The connection must be operated by a qualified, TVX-trained technician.

### INSERTING THE BATTERIES

The batteries should be correctly placed in the battery box below the recovery tank.

The type of battery must comply with CEI21-5 description.

Inserting the batteries as follows:

#### 一、 T45 Series (as figure 1)

1. Raise the recovery tank backwards.
2. House the batteries in the compartment, positioning the poles “+” and “-“opposite each other.
3. Connect the jumper cables (L) with plug (W) by tools.
4. Lay down the recovery tank.

#### 二、 T55/T70 Series (as figure 2)

1. Rotate the recovery tank (V) as far as it will go.
2. House the batteries (Z) in the compartment, positioning the poles “+” and “-“opposite each other.
3. Battery connector (W) is placed in the recess (2).

### CONNECTING THE BATTERIES (AS FIGURE 3)

1. Connect the batteries in series - using the jumper cables supplied (L) - to the poles “+” and “-“.
2. Connect the battery connector cable to the terminal poles “+” and “-“to obtain a voltage of 24V on the clamps. The battery connector (W) is put together with this Manual in one package.



You are advised to have the electric connections made by a qualified, TVX-trained technician. Any error would harm the operator and damage the machine.



Figure 1

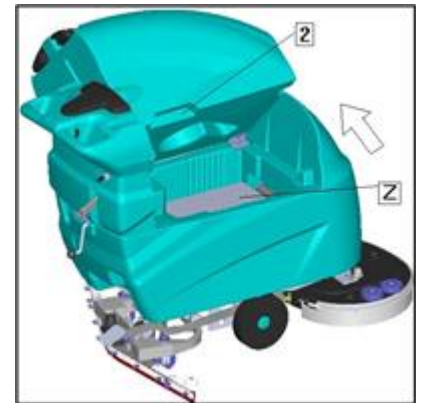
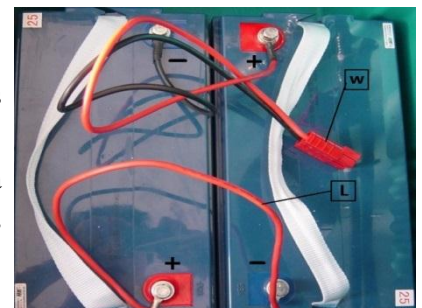

Figure 2



**BATTERY MAINTENANCE**

For maintenance and recharging, respect the instructions provided by the battery manufacturer.

Particular attention must be paid when choosing the battery charger, if not supplied, since there are different kinds according to the type and capacity of the battery.

**BATTERY DISPOSAL**

When the battery reaches the end of its working life, it must be disconnected by expert, trained personnel, then lifted (using the grips and suitable lifting devices) to remove it from the battery compartment.



危险废物  
Hazardous waste

Exhausted batteries are classified as dangerous waste. When disposing, observe the laws and regulations in force.

**RECHARGING THE BATTERIES**

In order not to cause permanent damage to the batteries it is essential to avoid their complete discharge: arrange the recharge within a few minutes of the switching on of the flashing "discharged batteries" signal.

NOTE: never leave the batteries completely discharged, even if the machine is not being used. While recharging, keep the recovery tank raised, supporting it with the cable, as shown in the figure. Check the battery charger is suitable for the batteries installed, in terms of both capacity and type.

Separate the machine connector (M) from the battery connector (W), and connect the battery connector (W) with battery charger for recharging.

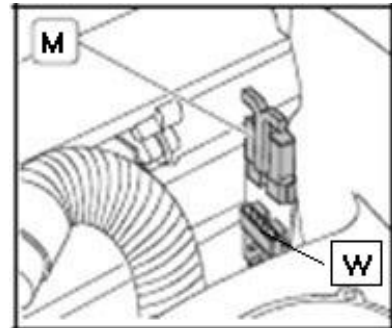

T55/T70



当心腐蚀  
WARNING CORROSION

Danger of exhalation of gas and leakage of corrosive liquids



Danger of fire: do not go near with free flames.

**BATTERY INDICATOR**

On the instrument panel of the machine there is a monitor indicating the battery charge status. If the upper line contains 8 light indicators, the battery charge level is 100%. If the edges of the indicators are flashing, this means the batteries are run down.



A few seconds after the last indicator on the monitor has flashed, the brush motor will automatically switch off. With the remaining charge it is



T45

possible to complete the drying process before recharging.

**INSTRUMENT PANEL COMPONENTS (T55/T70)**

- . Battery level / hour-counter display
- H. MENU button for the monitor of the hour-counter battery level
- I. Speed level key



**DISPLAY**

**Display information when active:**

Brand: **TVX**  
 Specification: **T65BT-06**

**Display information when work:**

Battery level:  (flashing at low level)  
 Total functioning time: **00000: 00** (hour: minute)  
 Battery voltage: **BAT=24.0**  
 Functioning time at present: **00: 00** (hour: minute)

- Short press “MENU”, recycling shows the contents above.
- Long press“MENU”for ten seconds, total functioning time would return to zero.



**SETUP**

Setting up the operating mode according to the type of battery (default setting: **AGM** mode)

- Long press “MENU”, after turning on the key switch.  
 Log in the setting screen after 10 seconds:

**Battery**

sort : **AGM**      Liquid electrolyte lead traction batteries.

**Battery**

sort : **WET**      Lead-acid battery composed of liquid plumbic acid.

**Battery**

sort : **GEL**      Sealed traction batteries with gas recombination or gel technology.

- short press “MENU”, circularly select the batteries.  
 Long press “MENU”for three seconds, save and log out.

## HOW IT WORKS

### Walking Drive (T45B、T45E、T55B Not Applicable)

- To make the machine walk forward, pull the control lever back, adjusting the speed adjuster. To walk faster, rotate the adjuster clockwise; anticlockwise on the contrary.
- To make the machine walk backward, push the control lever back forward, adjusting the speed adjuster. To walk faster, rotate the adjuster clockwise; anticlockwise on the contrary.
- Drop the squeegee, the machine could walk forward only.

### Brush Drive

- Drop the base by means of pedal, pulling the control lever back to active brush. It will not work if the base is raised.

### Suction Drive

- Rotate the lifting lever (anticlockwise), pulling the control lever back to start the squeegee. It will stop working after sixty seconds if clockwise rotate the lifting lever.

## ERROR AND SAFEGUARD

NO OPERATION ALLOWED after the batteries ran down (when battery level symbol was flashing).

The flashing “WalkErr” symbol indicates an overload failure of walking drive.(45L Not Applicable)

The flashing “AbsrbErr” symbol indicates an overload failure of absorbing drive.

The flashing “BrushErr” symbol indicates an overload failure of brush drive.

## REAR COMPONENTS

- A. Control lever
- B. Key switch
- C. Hand brake
- D. Lever to raise the squeegee
- E. Pedal to raise the brushes

## SIDE COMPONENTS

1. Water solution inlet cap
2. Handle to raise the recovery tank
3. Handle to raise the recovery tank cover

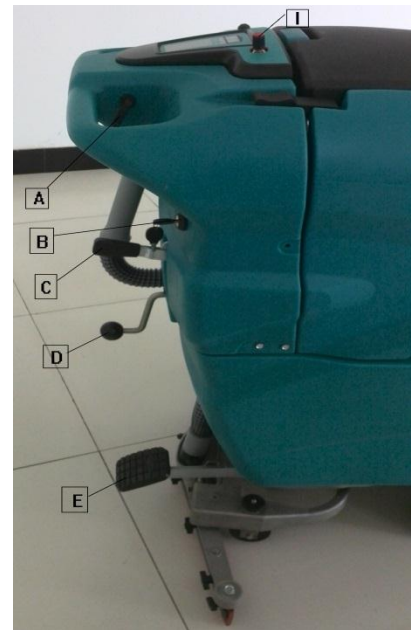

### ASSEMBLING THE SQUEEGEE T45

For packaging reasons, the squeegee is supplied disassembled from the machine, and must be assembled on the machine connection. Fix the squeegee to the holder with bolt (A), as figure.



### ASSEMBLING THE SQUEEGEE T55/70

For packaging reasons, the squeegee is supplied disassembled from the machine, and must be assembled on the machine connection. Fix the squeegee(Y) to the holder with spring (Q), and connect suction tube (T) with the sleeve (P) as figure.

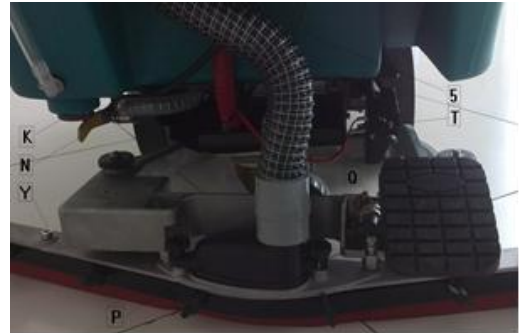

### ADJUSTING THE HEIGHT OF SQUEEGEE

Adjust the height according to the rubber as follows:  
Rotate the adjuster (J) clockwise to raise the squeegee, anticlockwise on the contrary.



Rotate the adjuster of both sides simultaneously to keep the squeegee parallel with the ground.

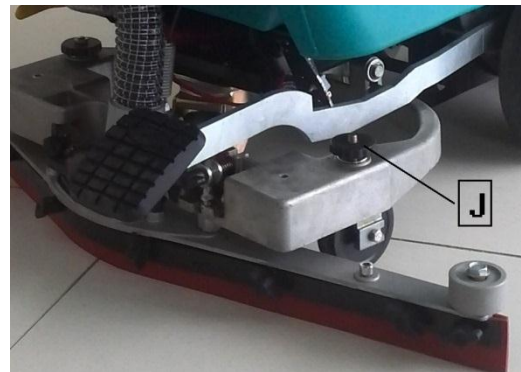

### ADJUSTING THE SQUEEGEE INCLINATION

During working operation, the rear rubber is tilted slightly backwards (by about 5mm) in a uniform way for its whole length. If it is necessary to increase the bend of the rubber in the central part, you must tilt the squeegee backwards, rotating the adjuster (7) anticlockwise, and then fix the set screw.

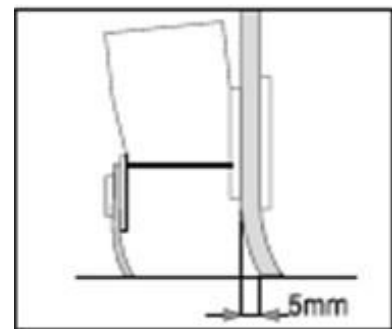

### RECOVERY TANK

Rotate the recovery tank as far as it will go, using the side handle.

Check the suction tube (T), the drainage tube(S) and the recovery tank is correctly connected.

Check the suction tube (T) and the squeegee (P), the drainage tube(S) and the cap of drainage tube (F) is correctly connected further.

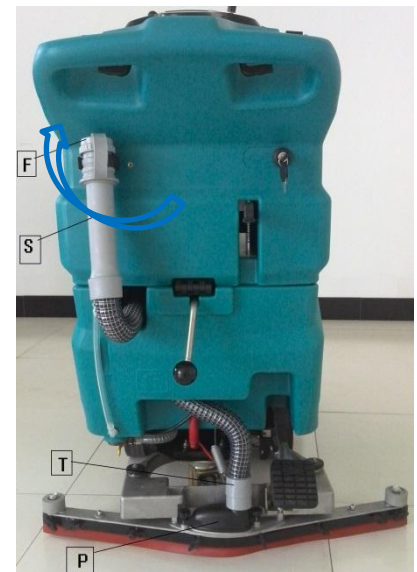

### SOLUTION TANK

Remove the front inlet cap (R), fill it with clean water.

### CLEAN WATER

Fill the solution tank with clean water at a temperature not exceeding 50 °C. Add the liquid detergent to the tank in the concentration and manner indicated on the detergent manufacturer's label. The formation of excess foam could damage the suction motor, so use only the minimum amount of detergent necessary. Cover the tank with cap(R).

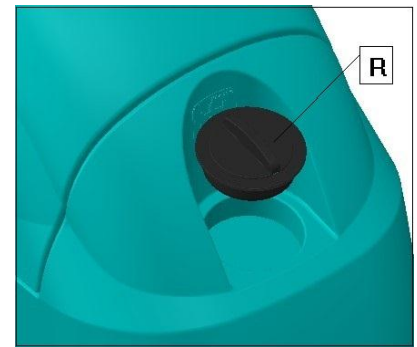

You are advised to always use low foam detergents and add a little anti-foam reagent to solution tank. Do not use pure acids!

### ASSEMBLING THE SPLASH GUARD RUBBERS

For packaging reasons, the splash guard rubbers are supplied disassembled from the machine.

To connect the rubber, remove the rubber-pressing blades and unthread the spring hook from the connection screw. Assemble the splash guard rubbers as figure. Wind the rubber all around the base, and reattach the blades.

Be careful not to invert the right blade with the left one, as they are not the same.



### ASSEMBLING THE BRUSH

This series of devices equipped with an automatic brush- assembling system. Follow the instructions:

1. Raise the base by means of the pedal (E).
2. With the base up, place the brushes into the plate housing beneath the base,
3. Drop the base by means of the pedal (E).
4. Turn the key (B) to position “1”.
5. Pull the control lever (A) to start the device until the brush is locked into place.

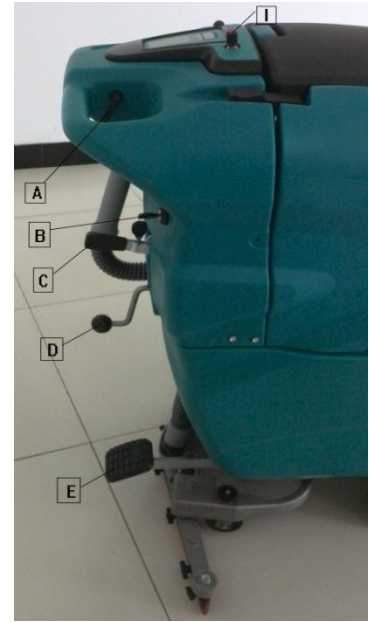

### ASSEMBLING THE BRUSH (MANUAL VERSION)

1. Raise the base by means of the pedal (E).
2. Turn the key (B) to position “0”.
3. Drop the hand brake (C).



This operation must be carried out after switch off the power supply to protect your hands.

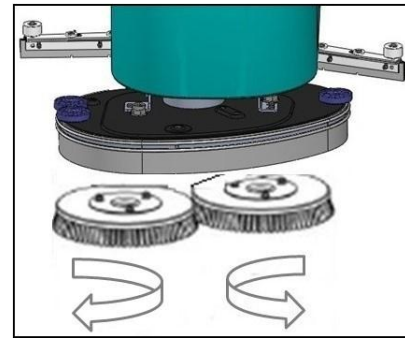

4. With the base up, place the brushes into the plate housing beneath the base, turning the brushes until the three pins enter the niches in the plate itself; turn until the pin is pushed towards the coupling spring and is locked into place. The figure shows the rotation direction for coupling the brush.

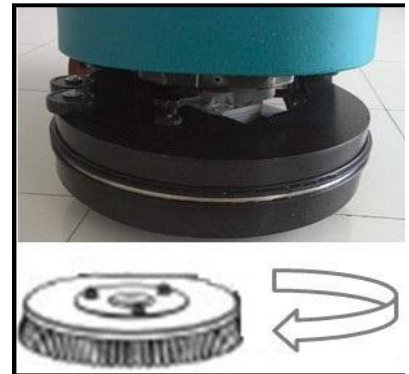

5. You are advised to daily exchange the position of two brushes. If the brushes curl after a period of time, please put them back to the initial position, to avoid extra consumption of the brush motor. (T70)

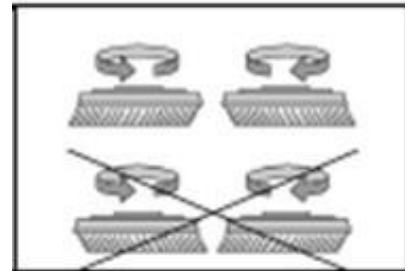

## II .WORK

### PREPARING TO WORK

1. Connect the connector (M) to the batteries.
2. Turn the key (B) of the main switch to position “1” .The monitor (H) on the instrument panel will immediately come on.
3. Rotate the water tap (N) to adjust the flow. Select an appropriate level. The water falls automatically while the brushes are turning. You are advised to adjust the level according to the movement speed and the type of floor and dust.
4. Release the pedal (E) and lower the base
5. Lower the squeegee, rotating the squeegee lifting lever (D).
6. Check the brake (C) is off.

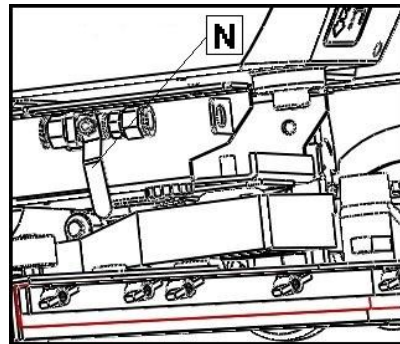
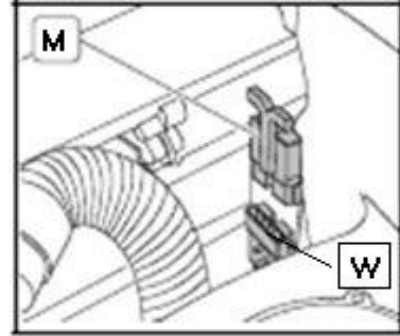

### WORKING

Walk forward: Pull the control levers (A) to activate the brushes; the machine will begin to move. Adjust the movement speed by rotating the adjuster (I). (T45B、T45E、T55B machine adopts manual drive mode, so its speed and direction is determined by operators.)

Walk backward: To activate the reverse direction, just push the control levers (A) forward. (Pull back T45B、T45E、T55B machine, with the squeegee raise).



When making even brief reverse movements, check the squeegee is raised.

During the first meters, check there is sufficient solution and that the squeegee dries perfectly. The machine will now start to work efficiently until the detergent solution runs out.

When there is an operation risk, loosen the lever (A) and pull down the emergency brake (C) immediately to stop the machine. Restart the machine after trouble shooting, and check the hand brake (C) is released before move.

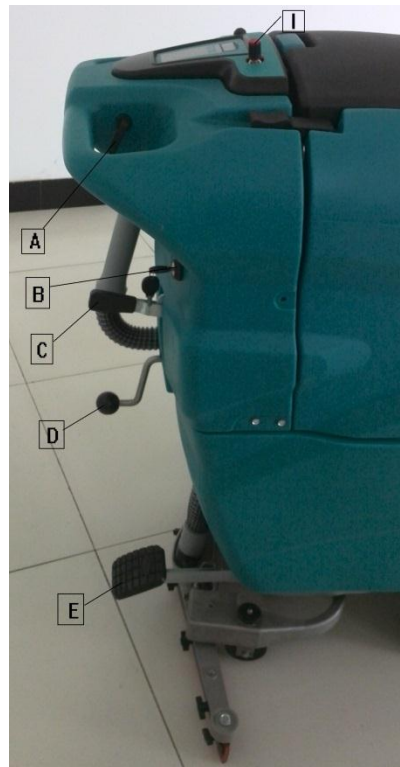



**OVERFLOW DEVICE**

The machine is fitted with a float which intervenes when the recovery tank is full, causing the suction tube to close. In this case, it is necessary to empty the recovery tank, removing the cap of the rear drainage hose.



This operation must be carried out using gloves to protect against contact with dangerous solutions.

**WORKING (VERSION WITH TRACTION SYSTEM)**

The machine is equipped with a traction control system that contains a forward gear and a reverse gear.

Active the machine:

Turn the key switch to start the machine, three seconds later, pull the lever (A) to move forward; push the lever (A) to activate the reverse direction.



When making even brief reverse movements, check the squeegee is raised.

**PARKING BRAKE (VERSION WITH TRACTION SYSTEM)**

The machine is equipped with an EBA (Electronic brake assist) system. It could be active by loosening the lever (A).

If necessary, pull down the hand brake (C) when parking.

**AT THE END OF THE WORK**

1. Raise the base by means of the pedal (E).
2. Raise the squeegee by means of lifting lever (D).
3. Bring the machine to the place provided for draining the water.
4. Turn the key switch (B) to "OFF" to switch off the machine.
5. Pull the hand brake (C).
6. Remove the drainage tube (S) from its compartment.
7. Unscrew the drainage cap (F) and empty the recovery tank.



These operations must be carried out using gloves to protect against contact with dangerous solutions

8. Disassemble the brushes and clean them with a jet of water (to disassemble the brushes, see "DISASSEMBLING THE BRUSHES" below).

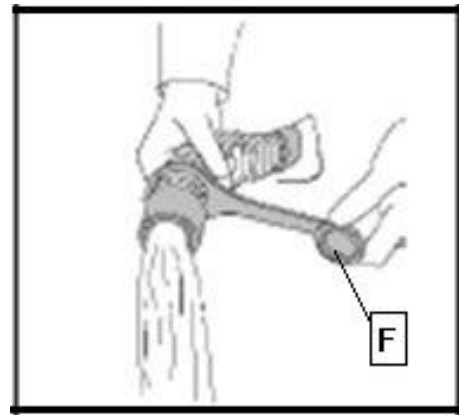
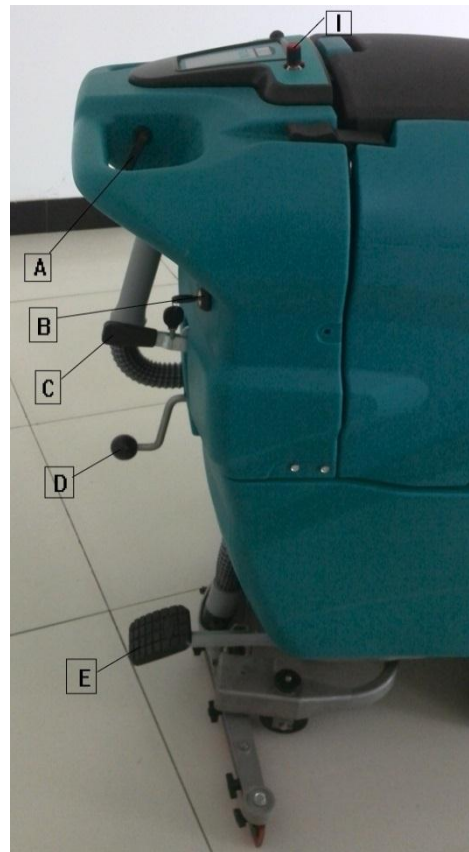

### III. DAILY MAINTENANCE

#### CLEANING THE RECOVERY TANK

1. Remove the drainage tube(S)
2. Remove the cap (F) and empty the tank.
3. Raise the recovery tank cover (H);
4. Rinse the inside of the tank well with a jet of water.

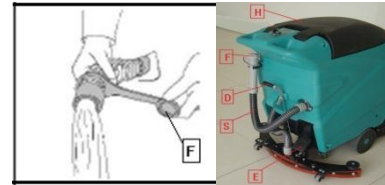

These operations must be carried out using gloves to protect against contact with dangerous solutions.

5. Raise the recovery tank cover
6. Rotate the stopper anticlockwise and remove it.
7. Rinse all the elements with a jet of water
8. Reassemble all the elements

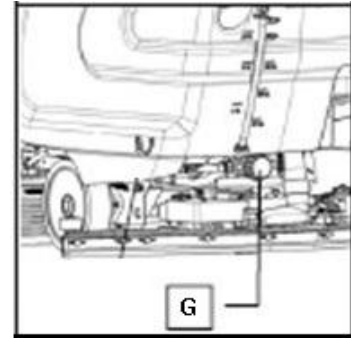

#### CLEANING THE SUCTION FILTER

1. Remove the suction filter (G) from its seat.  
Use a jet of water to clean the walls and base of the filter.
2. Reassemble all the elements.

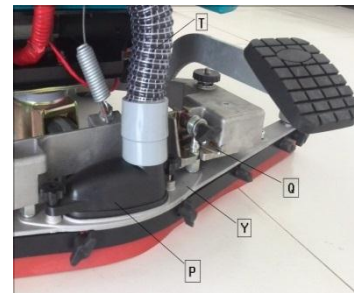

#### CLEANING THE SQUEEGEE

Check the squeegee is always clean, for better drying results, To clean it you must:

1. Remove the tube (T) from the squeegee.
2. Release the Squeegee fixed handle (P).
3. Remove the squeegee.
4. Carefully clean the inside of the squeegee (Q) and rubbers.
5. Reassemble all the elements.

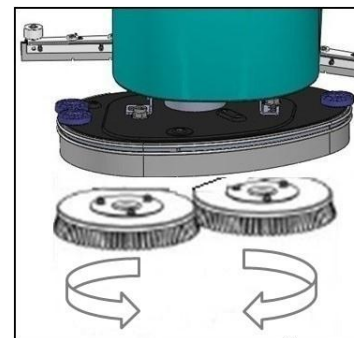

#### DISASSEMBLING THE BRUSH

There are two versions to remove the brushes:

Disassembling the brush (Automatic version)

1. Raise the base, using the pedal (E).
2. Stop the machine moving by applying the hand brake (C).
3. Turn the key to position “!”. Press the brush release button until the brush comes out of the brush-holder plate seat.



During this operation, checks there are no people or objects near the brushes.

Disassembling the brush (Manual version)

1. Raise the base, using the pedal (E).

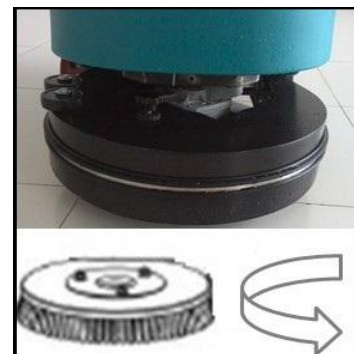

2. Stop the machine moving by applying the hand brake (C).
3. With the base up, rotate the brush until it comes out of the brush-holder plate seat, as shown in the figure.

### CLEANING THE BATTERY BOX

Empty the battery box by the tube beneath the recovery tank at rear of the machine, check there is no fluids.



This operation must be carried out using gloves to protect against contact with dangerous solutions.



Danger of exhalation of gas and leakage of corrosive liquids



Danger of fire: do not go near with free flames.

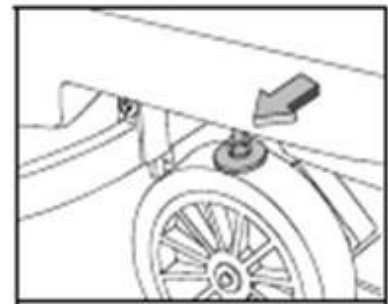

## IV. WEEKLY MAINTENANCE

### CHECK THE WHEEL BRAKE

Every week, check the distance between the work brake pads and the wheels. If necessary, adjust them by means of the nuts, so they are at a distance of 3mm when homed. (T55/T70)

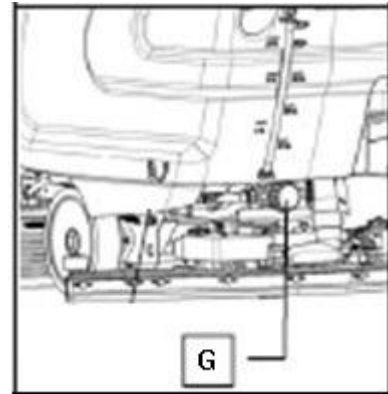

### CLEANING THE SOLUTION FILTER

1. Loosen the cap of the solution filter.
2. Remove the filter (G) and rinse with a jet of water
3. Reassemble the filter and tighten the cap.



To empty the solution tank, loosen the knob (K), releasing water.

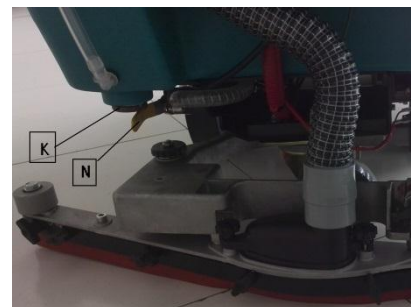

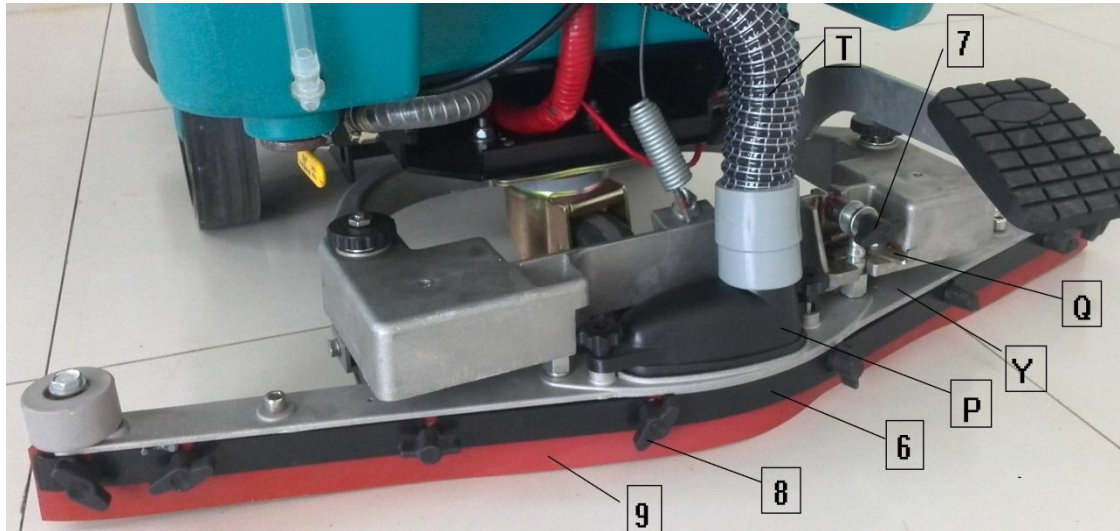

T55/T70

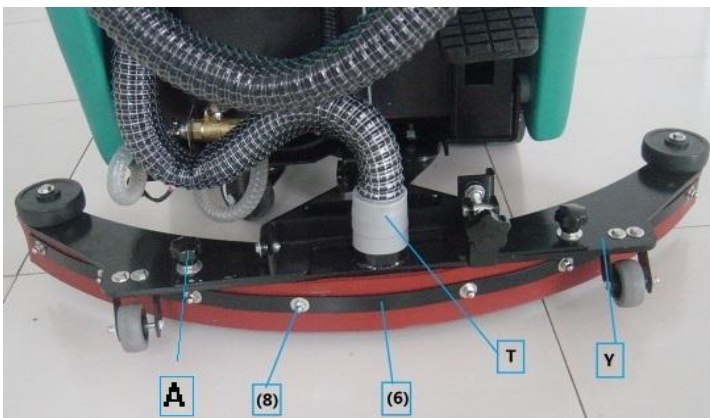

T45

### REPLACING THE SQUEEGEE RUBBERS

Check the state of wear and tear of the squeegee rubbers and, if necessary, replace them as below:

1. Remove the tube (T) from the sleeve (P) on the squeegee.
2. Rotate the spring (Q) clockwise.(T55)
3. Unthread the squeegee (Y).
4. Loosen the wing nuts (8) that block the rubber-pressing blade and the strengthening profile.
5. Reassemble the rubber (9), the strengthening profile and the rubber-pressing blade, and then tighten the wing nuts.

### CLEANING THE SQUEEGEE TUBE

Every week, or whenever suction seems to be unsatisfactory, check the squeegee tube is not obstructed. To clean it, proceed as follows:

1. Remove the tube (T) from the sleeve on the squeegee
2. Remove the other end of the tube from the recovery tank.
3. Wash the inside of the tube with a jet of water (from the tank side).
4. Reassemble the tube.



Do not wash the connecting tube between the suction pump and plug.

**CLEANING THE WATER INLET COMPONENTS**

1. Raise the recovery tank cover (H).
2. Remove the water inlet cover (6) and sponge (7).
3. Use a jet of water to clean the sponge (7).
4. Reassemble all the elements when the sponge (7) is dry thoroughly.

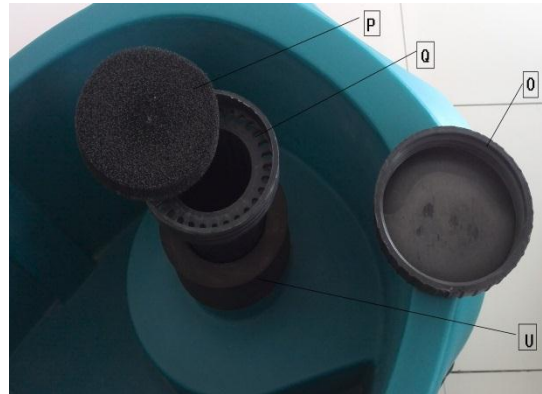

**CLEANING THE SOLUTION TANK**

1. Remove the cap of the solution tank(R).
2. Rinse the inside of the tank with a jet of water.
3. Loosen the knob (K), and empty the solution tank.



These operations must be carried out using gloves to protect against contact with dangerous solutions.

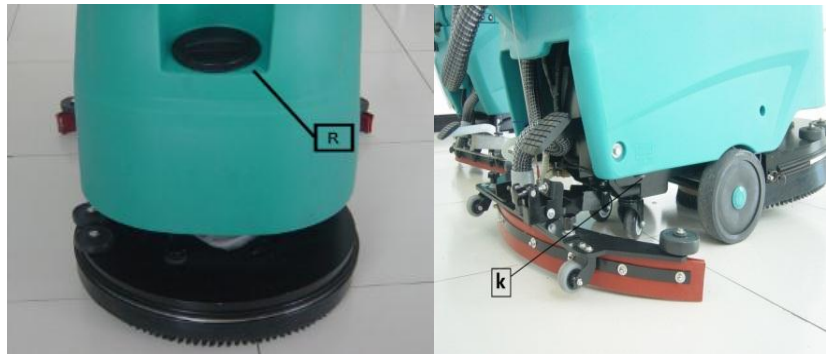

**V. TROUBLE SHOOTING**

**INSUFFICIENT WATER ON THE BRUSH**

- Check the water tap is turned on.
- Check there is water in the solution tank.

**THE MACHINE DOES NOT CLEAN WELL**

Check the state of wear and tear of the brush and, if necessary, replace it (the brush must be replaced when the bristles are about 15mm long). Please refer to “DISASSEMBLING THE BRUSH “and “ASSEMBLING THE BRUSH”.  
 Use a different kind of brush to the one fitted as standard. For cleaning floors where the dirt is particularly resistant, we recommend the use of special brushes supplied upon request and according to needs (see “CHOOSING AND USING THE BRUSHES”).

**THE SQUEEGEE DOES NOT DRY PERFECTLY**

- Check the squeegee rubbers are clean.
- Adjust the inclination and height of the squeegee (see the “ADJUSTING THE SQUEEGEE INCLINATION AND HEIGHT” paragraph).
- Check the suction tube is correctly inserted in its housing on the recovery tank.
- Check the inner filter of the recovery tank is not dirty and if necessary, clean it thoroughly.
- Check the state of wear and tear of the brush and, if necessary, replace it.
- Check the suction motor is turned on.
- Check the wheels are adjusted.

**EXCESSIVE FOAM PRODUCTION**

Check that a low foam detergent has been used. If necessary, add a small quantity of antifoam liquid to the recovery tank.

Remember that, when the floor is not very dirty, more foam is generated. In this case the detergent solution should be more diluted.

**VI. CHOOSING AND USING THE BRUSHES****POLYPROPYLENE BRUSH (PPL)**

Used on all types of floors. Good resistance to wear and tear, and hot water (no greater than 60 °C). The Polypropylene brush is non-hygroscopic and therefore retains its characteristics even when working in wet conditions.

**NYLON BRUSH**

Used on all types of floors. Good resistance to wear and tear, and hot water (no greater than 60 °C). The Nylon brush is hygroscopic and easy-extended; as a result it cannot retain its characteristics when working in wet conditions.

**ABRASIVE BRUSH**

The bristles of this type of brush are extremely hard. It is used to clean very dirty floors. To avoid floor damage, work only with the pressure strictly necessary.

**STEEL BRUSH**

It is made up of steel wire and artificial fiber blends and used to clean rough roads, floors with big joints or dirt which is difficult to clean up.

**THICKNESS OF THE BRISTLES**

Thicker bristles are more rigid and are therefore used on smooth floors or floors with small joints.

On uneven floors or those with deep joints, it is advisable to use softer bristles which can enter the gaps more easily.

Remember that when the bristles are worn and therefore too short, they will become rigid and are no longer able to penetrate and clean deep down. In this case, like with over-large bristles, the brush tends to jump.

**PAD HOLDER**

The pad holder is recommended for cleaning shiny surfaces.

There are two types of pad holder:

The traditional pad holder is fitted with a series of anchor points that allow the abrasive floor pad to be held and dragged while working.

The CENTRE LOCK type pad holder not only has anchor points, but also a snap-type central locking system in plastic that allows the abrasive floor pad to be perfectly centered and held without any risk of it becoming detached. This type of dragging device is recommended above all for machines with more than one brush, where the centering of the abrasive discs is difficult.